

April 2006

Cost Basis of Grinding vs. Machining Machines

Brian J. Berk

Worcester Polytechnic Institute

Ian A. Phillips

Worcester Polytechnic Institute

Vincent Michael Taormina

Worcester Polytechnic Institute

Follow this and additional works at: <https://digitalcommons.wpi.edu/mqp-all>

Repository Citation

Berk, B. J., Phillips, I. A., & Taormina, V. M. (2006). *Cost Basis of Grinding vs. Machining Machines*. Retrieved from <https://digitalcommons.wpi.edu/mqp-all/837>

This Unrestricted is brought to you for free and open access by the Major Qualifying Projects at Digital WPI. It has been accepted for inclusion in Major Qualifying Projects (All Years) by an authorized administrator of Digital WPI. For more information, please contact digitalwpi@wpi.edu.

Project Number: YR-0505

COST BASIS OF GRINDING MACHINE VS. MACHINING MACHINES

A Major Qualifying Project Report:

Submitted to the Faculty

of the

WORCESTER POLYTECHNIC INSTITUTE

In partial fulfillment of the requirements for the

Degree of Bachelor of Science

by

Brian Berk

Ian Phillips

Vincent Taormina

Date:

Approved:

Professor Kevin Rong, Major Advisor

Professor Yong-Mo Moon, Co-Advisor

Abstract:

Grinding and machine tool machining are separated by a gap in technological knowledge. This project investigated the gap between the two areas in a functional comparison. The two methods were found to be comparable with regards to hard materials and high precision. The difference in price was accounted for by production volume. Grinding may find a way to keep a competitive edge in the marketplace if a common ground for function and performance provide for cheaper parts in the industry.

Table of Contents

Abstract:	ii
Table of Contents	iii
List of Figures	iv
List of Tables	iv
1. INTRODUCTION	1
1.1 SUMMARY	1
1.2 PROJECT REASONS AND MOTIVATION	2
1.3 BACKGROUND ON GRINDING	2
1.4 BACKGROUND ON METAL CUTTING	6
2. FUNCTIONAL AND COMPONENT COMPARISON	9
2.1 INTRODUCTION	9
2.1.1 MACHINE TOOL COMPONENTS AND FUNCTIONS	9
2.2 SURFACE GRINDING VS. MILLING	10
2.3 OD GRINDING VS TURNING	15
2.4 FURTHERING THE ANALYSIS	20
3. TECHNICAL OUTPUT COMPARISON	22
3.1 INTRODUCTION	22
3.2 THE DRIVES	22
3.2.2 THE LATHE AND MILLING MACHINE	22
3.2.3 THE SURFACE GRINDER AND OD GRINDER	24
3.3 THE GUIDEWAY SYSTEM	24
3.4 THE BASE	25
3.5 ACCURACY	25
3.6 CONTROLS	27
4. RESULTS	28
4.1 VOLUME	28
4.2 PRECISION	29
5. CONCLUSIONS	30
REFERENCES	31
BIBLIOGRAPHY	31

List of Figures

Fig. 1.1 Basic motion of a planar grinding machine

Fig. 1.2 Grinding wheels

Fig. 1.3 Disks

Fig. 1.4 Other abrasive products

Fig. 1.5 Cutting process

Fig. 1.6 Milling

Fig. 2.1 Commonalities in machine tools

Fig. 2.2 Vertical rotary cutting

Fig. 2.3 Horizontal rotary cutting

Fig. 2.4 Linear scales

Fig. 2.5 OD grinding

Fig. 2.6 Lathe cutting tool and chuck

Fig. 3.1 Work-piece accuracy

List of Tables

Table 2.1 Surface Grinder Components and Functions	11
Table 2.2 Milling Machine Components and Functions.....	13
Table 2.3 OD Grinder Components and Functions	16
Table 2.4 Lathe Components and Functions.....	18

1. INTRODUCTION

1.1 SUMMARY

Grinding machines and metal cutting machines are both used for the manufacture of finished products. This project is focused on the functions of the parts used in the makeup of grinding machines and metal cutting machines.

The project was proposed as an investigation of the high price of grinding machines. This price was to be analyzed in comparison to the lower price of commercially available metal cutting machines. The gap analysis would focus on the cost differences between machines of similar function and capabilities, after a functional analysis was performed on varying machine types.

Existing data on the two machine types puts them in two distinct classes of production. Grinding is seen as a high precision, superior surface finish style process. Metal cutting machining is seen as a rougher, yet faster and cheaper alternative which is far more flexible in machine design. These judgments are based on stock version models, which are not comparable by function, and cast a biased view.

Once broken down into comparable function types, such as outer-diameter (OD) grinding and hard-turning or surface grinding and milling, it was possible to form a related cost analysis. These common purpose machines were compared on levels of the same functionality, and the results drawn that when on the same plane of specifications there was no considerable cost difference. The cost was attributed more to the demand called for by the different machines in their most common forms. Due to the natural higher precision of grinding machines, and their more specified production, they were

produced in smaller numbers and would cost more. We found this production level to be the major factor in cost difference between the machine types.

1.2 PROJECT REASONS AND MOTIVATION

This project was presented as a question as to why grinding machines are so much more expensive than metal cutting machines. Grinding machines on average cost \$350,000 while metal cutting machines are around \$75,000. There had been no previous work done that seemed to link the functions to the price difference, and it was thought that there was a component factor to the price difference. It was hoped that a difference could be observed, and possibly redesigned or isolated to try and reduce the cost of grinding machines. This would all come as a result of understanding the differences between the machine types, and relating them to one another.

1.3 BACKGROUND ON GRINDING

Common uses for grinding are in many different fields of industry. Grinding is the only process that can produce the finish and tolerances needed for jet turbine engine blades. Grinding is also the process used to obtain the finish on silicon used for computer chips. Grinding is also used to make the drill bits used in its metal cutting counter parts.

These forms of grinding all utilize the same basic principles.

Grinding is a fundamental material removal process. Basic grinding involves a hard rough surface passing over a softer material, and removing parts of the softer

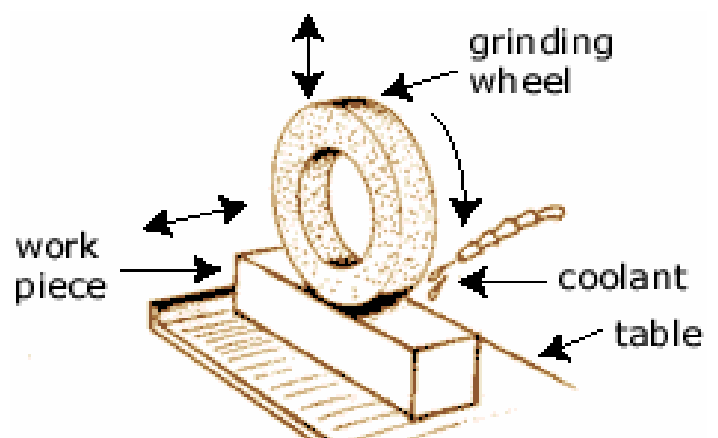

Figure 1.1 – Basic motion of a planar grinding machine

material. Industrial grinding is based around an imperfect hard surface rotating at a high number of revolutions per minute (rpm) and coming in contact with the stock material that is to be removed. The imperfect surface is commonly called an abrasive, and can be either smooth or rough depending on the desired finish quality. The process is one of blunt force, with the material removed and large frictional forces resulting. A visual example of a grinding system is in Figure 1.1.

The material removal process can be explained as a four step process. A simple example of grinding is a stone on a metal blade. The first step is the primary contact between abrasive and stock piece material. A cutting motion occurs, in which the abrasive material digs into the stock piece. The abrasive proceeds to push the material out of the way, forming a small clump. This clump is then forced by another abrasive piece to go beyond the point of the stock materials plasticity. The clump is then broken off by a weakening of the moved material. Repeating this action on a wide abrasive service at thousands of rpm, or in a repetitive linear motion, causes many small clumps or chips to be formed.

The grinding wheels for an operation can vary in both size and shape depending on the intended result. Different styles of abrasive creation allow for custom shapes to be



Figure 1.2 Grinding Wheels

achieved. Standard grinding wheels are formed out of abrasives mixed with a bonding agent, which is put into molds to form wheels (Figure 1.2). These circular shapes wear away as used, but can be reshaped as that they are all abrasive and bonding. Grinding wheels can also be sections of abrasive on discs shaped like saw

blades (Figure 1.3), and are used in a slicing motion. Coated abrasives are those formed by gluing or cementing an abrasive onto a pre-formed shape so that the abrasive takes on the same shape. Bonding the abrasive to different shapes allows custom detailing without the need for multiple grinding bits. This coating process also works on flat discs with abrasive on the circular side, such as a rotary sander.



Figure 1.3 Disks



Figure 1.4 Other Abrasive products

Since the nature of grinding is to use friction as a means of material removal, it has side effects which must be dealt with. The high speed of the spindle and grinding surfaces causes both large amounts of heat and vibrations. Special coolant systems are designed to handle the large amounts of heat, so that the stock material or abrasive are not negatively affected. As well, the coolant helps to move away chips of waste material from the process. Vibrations are a threat to the finishing process, as they cause the material to move in inconsistent patterns. Advanced bearing systems are employed in the spindle arm, housing, and motor rotors to keep vibration from affecting the grinding tool path. Special guide ways and dampening materials are also used to keep vibrations from reaching the final product.

The grinding process is known as being able to provide a superior surface finish during the material removal process. When using a finer abrasive wheel, the finished

product can be produced at the same time as the initial material removal. This allows a single shaped bit to do both the rough removal and finishing in a single pass.

Grinding has several style variations for application. First is a type of grinding that could be referred to as planar grinding. Surface grinding is a planar system, in which a band of abrasive material, a wheel of abrasive, or a disk of abrasive is lowered onto a surface to take off a depth of material. The material is held in place while the grinding surface moves across or is lowered into the material. Creep feed grinding is an adaptation of surface grinding which introduces a moving stock material into the path of a rotating abrasive wheel. This system then removes the material to the level of the grinding surface and no further.

The other type of grinding can be called cylindrical grinding. Outer-diameter (OD) grinding is a system in which grinding surfaces are rotated, and a rotating stock piece is introduced next to the abrasive wheel. This results in a circular shape and form, and the system comes in two versions: through-feed and in-feed. Through-feed OD grinding introduces a stock piece at one end of the abrasive materials, and it passes across the abrasive to continue along the axis of motion until it has passed the entire process. In-feed OD grinding inserts a stock piece next to or between abrasive materials, and then removes the piece from the same direction it was inserted. Inner-diameter (ID) grinding is another cylindrical style in which an abrasive wheel is inserted into the stock piece along an axis to reshape the inner features. This is an in-feed only operation.

Grinding requires both high speeds and high stiffness in the machines. The high speeds are needed to produce enough friction with the stock piece to take out chips of material, without stopping the rotation of the wheel. These speeds combined with the

contact create large amounts of vibrations throughout the entire machine. High stiffness and vibration dampening materials and parts are used to keep the precision of the operation in a tight range.

1.4 BACKGROUND ON METAL CUTTING

Metal cutting is a process that is very similar to the techniques used in the cutting of softer materials. The methods of material removal were adopted from those used in wood shaping, and are almost identical. The basis of the method is to insert a wedge of tool between sections of material, and force the upper section off of the rest of the stock piece.

In a more detailed form, the process starts with a sharpened tool. This tool can be either fashioned as a straight, chisel like form or a circular rounded drill bit. The

sharpened edge digs into the stock piece, and acting with its forward leverage, lifts the upper material out of place. When the stock material has reached its plastic limit, the chip will fly off (Figure 1.5). This process removes larger chunks of material, and depends heavily on very sharp tools.

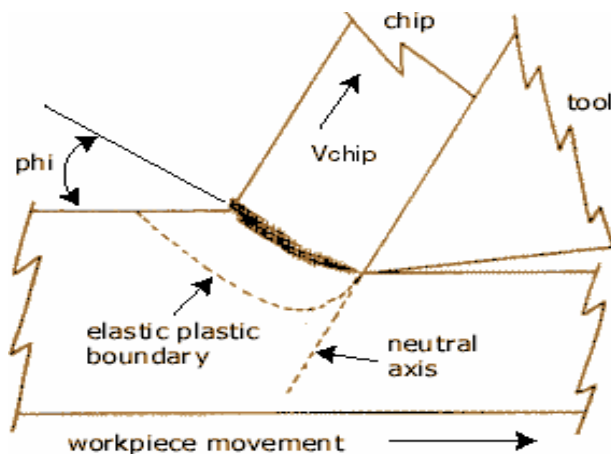

Figure 1.5 Cutting Process

Metal cutting also produces significant amounts of heat, and the tools need lubrication so as not to slide across the stock piece surface. The cooling system is designed to provide both a way to remove excess heat and allow the cutting to continue.

The removal of material by metal cutting is typically a rough removal method, and so a superior surface finish is not expected.

There are two major types of metal cutting machines. Milling uses different shape and size drill bits to remove the material of a stationary stock piece. The machine tool

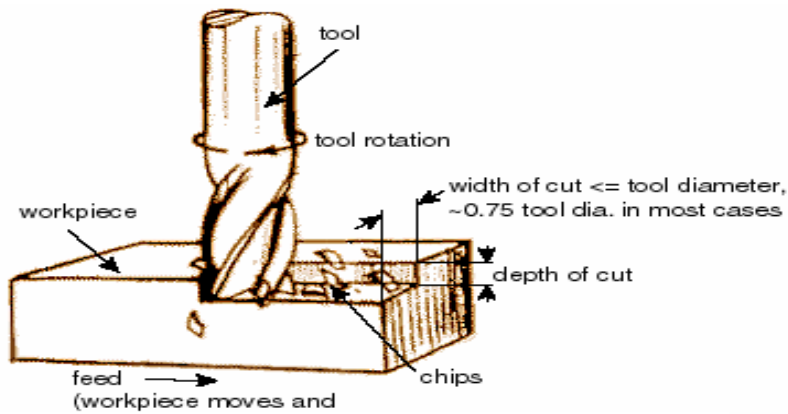

Figure 1.6 Milling

arm can have movement along two axes, or up to five axes. The bit will be lowered into the material, and can be used to bore holes or then proceed to move

laterally and take off a layer of material in the tool path (Figure 1.6). This path can be altered to form complex designs and patterns.

Hard-turning is a form of metal cutting machining which utilizes a moving stock piece and a rotation stationary tool. One end of the stock piece is held in a chuck, the other attached to a spindle motor. The stock piece is rotated so as to bring a symmetrical cutting action. The tool piece is inserted at an angle near to perpendicular to the axis of rotation. This process results in a circular cut stock piece, as it has taken off all the unrounded sections of material. Hard-turning is different than regular turning in that it deals with “hard” materials and creates for a better comparison with grinding machines.

Grinding machines and metal cutting machines both come in many varieties. Knowing how both works provided the basis of understanding where costs would come from in relation to machine necessity. If a cost was capable of being eliminated after it

was discovered there was no functional reason for the cost, it would be necessary to know the functions of the system first.

2. FUNCTIONAL AND COMPONENT COMPARISON

2.1 INTRODUCTION

All machine tools, no matter the type, are used for a similar purpose. Simply put, for shaping parts. Therefore, in all machines, there must be a cutting edge and a work piece. Furthermore, there must be relative motion between the two. This translates to motors, slides and ways. When in contact, the tool and work piece interaction will create considerably large cutting forces so there must be sturdy holders and strong frames involved. These are parts in general, but what about specific materials used and such? The amount of force needed to make a 2 inch cut in a block of AISI 4340 steel is going to be the same regardless of the cutting process. Therefore, it is not out of reason to assume that, for a particular part, all machine tools will have similar materials used, motor powers, mechanisms, design etc¹. In this section we will compare the functions of our machine tools and observe whether or not they match up. More specifically, we will compare the lathe functions to the OD grinder and the milling machine functions to the surface grinder. By exposing any main functional differences we may uncover some reasons why grinding machines cost what they do.

2.1.1 MACHINE TOOL COMPONENTS AND FUNCTIONS

As stated above, machine tools all have a commonality about them. Before getting lost in the details about the components and functions of each particular machine tool, it is important to look at the machine tools in general to gain perspective. In his four

¹ Nowadays, most machine tools are created to shape all different kinds of parts in order to increase the machines versatility. As a result, we chose machines as closely related in function as possible.

volume series on machine tools, Manfred Weck shows us the functional commonalities between all machine tools (Figure 2.1).

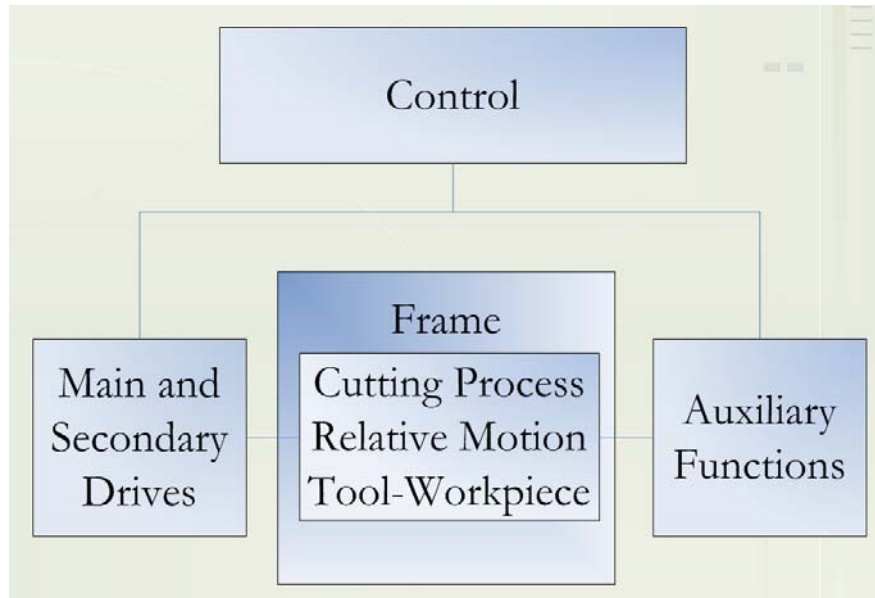

Figure 2.1 Functional and component commonalities in machine tools

Weck has divided the machines into four main functions: control, auxiliary functions (i.e. coolant systems, waste systems), tool-work piece relative motion, and drives. With this in mind, we can move on to our specific machine tool pairs to make comparisons.

2.2 SURFACE GRINDING VS. MILLING

Surface grinding and milling both involve removal of material from the top surface of a work piece. In this case the top surface of the work piece is flat. Where the milling machine uses a rotary action motion *parallel* to the top plane of the work piece

(Figure 2.2), the surface grinder has rotary action motion *perpendicular* to the surface² (Figure 2.3).

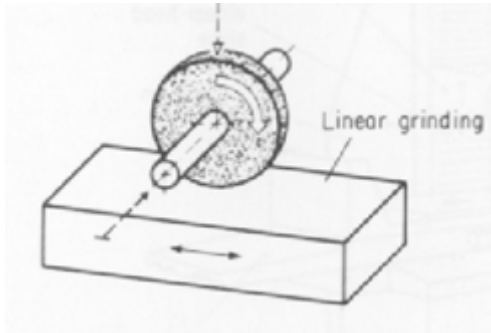

Figure 2.2 Vertical rotary cutting

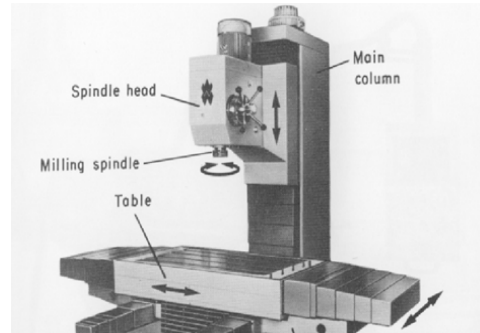

Figure 2.3 Horizontal rotary cutting

Both processes involve a reciprocating table for work piece translation and work head motion on the other two axes. The following shows the components and functions involved in surface grinding (Table 2.1). Highlighted are the items unique to that machine.

Table 2.1 Surface Grinder Components and Functions

COMPONENT	FUNCTION
Surface Grinders	Cuts and shapes parts
Wheel Head	Contains and vertically moves grinding wheel and main spindle
Spindle (non-motorized)	Holds and rotates the cutting tool
Shaft	Rotates the cutting tool
Bearings (general)	Holds shaft and allows rotation
Inner Race	Connects shaft to Bearings
Outer Race	Connects housing to bearings
Separator	Keep ball bearings in line
Ball Bearings	Allows motion between inner and outer race
Spindle Nose	Connects cutting tool to shaft
Spindle Housing	Contains spindle
Front Seal	Prevents incoming contaminants
Rear Seal	Prevents incoming contaminants

² There are many other surface grinding techniques with grinding wheels in the horizontal position, although our research showed that these were less common so they were excluded from our study.

Drawbar	Allows spindle nose release
Tool Holder	Secures the Tool in place
Spindle Mounts	Provides structural attachment for spindle
Wheel	Cuts the work piece
Wheel Mount	Supports the wheel, connects to spindle nose
Frame	Provides support for the work piece, cutting tool etc.
Base	Takes most of the machine load
Square Tubes	Provides for additional load support in the base
Bed	Supports the table
Column	Supports the wheel head
Table	Supports the work piece table
Ball screws	Provide stable motion to nut, in turn table/spindles
Shaft	Rotates and allows nut movement
Nut	Connects the shaft and the table
Mounts	Support the ball screw on each end
Bearings	Holds shaft and allows rotation
Inner Race	Connects shaft to Bearings
Outer Race	Connects housing to bearings
Separator	Keep ball bearings in line
Ball Bearings	Allows motion between inner and outer race
Hydrostatic Way System	Supports and moves the work piece
Way	Saddle track connected to the Base
Base	Stationary member connected to table
Saddle	Moving member and male section.
Fluid Pockets	Fluid Interface for relative way-saddle motion
Fluid Piping	Directs fluid (oil) to pockets
Head Drive System	Provides motion to grinding wheel
Spindle Motor	Rotates wheel (in direct wheel contact)
Rotor	Rotating metal
Stator	Stationary magnet
Table Drive System	Provides motion to the table
Servo Motor	Provides motion to the ball screws
Rotor	Rotating metal
Stator	Stationary magnet
Waste System	Directs the flow of contaminants and chips
Waste Sump	Waste collector
Flushing System	Protects parts from swarf
Special Seals	Keeps harmful grit out of parts
Control System	Controls speeds, feeds, motions etc.
Linear Scales	Provides positional feedback to the controls
Coolant System	Prevents heat damage to parts including work piece
Coolant Pump	Drives the flow of coolant to specific areas
Piping	Directs coolant flow
Coolant Nozzle	Outlet for Coolant
Truing System	Keeps the grinding wheel sharp
Diamond Tip	Grinding wheel cutting tool
Electrical System	Translates and manipulates electrical voltage

Now we will shed some light on the surface grinder's metal cutting counterpart, the milling machine (Table 2.2). Again, highlighted are the items unique to that machine.

Table 2.2 Milling Machine Components and Functions

COMPONENT	FUNCTION
Milling Machine	Cuts and shapes parts
Head	Contains and moves the main spindle and tool vertically
Spindle	Holds and rotates the cutting tool
Shaft	Rotates the cutting tool
Bearings	Holds shaft and allows rotation
Inner Race	Connects shaft to Bearings
Outer Race	Connects housing to bearings
Separator	Keep ball bearings in line
Ball Bearings	Allows motion between inner and outer race
Spindle Nose	Connects cutting tool to shaft
Spindle Housing	Contains spindle
Front Seal	Prevents incoming contaminants
Rear Seal	Prevents incoming contaminants
Drawbar	Allows spindle nose release
Spindle Mounts	Provides structural attachment for spindle
Tool	Cuts the work piece
Body	Provides support for the work piece, cutting tool etc.
Base	Takes most of the machine load
Column	Supports the head
Bed	Supports the work piece table (cast iron)
Table	For supporting and moving loads
Saddle	Moving member of slide
Hardened Steel Way Slides	For tool-work piece motion
Way	Saddle tracking wear surface
Base	Stationary member and male section
Retainer	Retains the saddle to the base
Lubrication Fitting	For pressure gun lubrication
Wiper	Provides protection to way surfaces from contaminants
Gib	Sets clearance between way and saddle
Gib Screws	Used to adjust Gib
Gib Screw Nuts	Locks Gib Screws
Gib Positioning Pin	For linear Gib positioning
Drive System	Provides motion to all moving parts/fluids
Spindle Motor	Provides motion to the spindle via shaft
Table Motor	Provides motion to the table via ball screw
Ball screws	Connected to table motor
Shaft	Rotates and allows nut movement
Nut	Connects the shaft and the table
Mounts	Support the ball screw on each end
Bearings	Holds shaft and allows rotation
Inner Race	Connects shaft to Bearings
Outer Race	Connects housing to bearings
Separator	Keep ball bearings in line

	Ball Bearings	Allows motion between inner and outer race
Waste System		Directs the flow of contaminants and chips
Waste Sump		Waste collector
Control System		Controls speeds, feeds, motions etc.
Coolant System		Prevents heat damage to parts including work piece
Coolant Pump		Drives the flow of coolant to specific areas
Piping		Directs coolant flow
Coolant Nozzle		Outlet for Coolant
Electrical System		Translates and manipulates electrical voltages

From these two lists we can pinpoint some of the main differences. There are many, but the most significant in terms of cost are the ways and the base³. With the grinding machine, we have the hydrostatic way and truing system as the main difference. There also exists a special flushing system for the harmful grit that comes off the grinding wheel. With these special flushing systems, there are special seals involved and also tougher materials used for parts that are resistant to corrosive wear. The grinding zone is more like a “war zone” as Edward Camp put it, president of the Service Network Incorporated. The Service Network specializes in the construction of Internal Diameter grinding machines. They also build and provide maintenance services for many other types of machines, including metal cutting machines with cutting edges of critical geometry. Within the hydrostatic way system, there are capillary coils⁴, for fluid transfer, and over time may develop hardening or “arteriosclerosis”, as Mr. Camp put it. Steve Mansur, business director of the Service Network, affirms that a forty five dollar coil can cost up to \$15,000 dollars to repair! Furthermore, in terms of achieving tighter tolerances, Mr. Camp says that in order to half the desired tolerance, the price goes up exponentially! Indeed, there exists a price to pay for precision.

³ From our research, the base and way system came up to be the two major cost contributors to the machine tool

⁴ These systems were not including in the functional comparison due to the fact that their actual “existence” were confirmed by a limited number of sources, opposed to the items in the diagram which are supported through an extensive number of sources.

2.3 OD GRINDING VS TURNING

OD Grinding and turning are processes used to cut and shape cylindrical parts. In both cases the work piece is held in a chuck and supported from the back by the tail stock. Furthermore, the piece is rotated in the chuck to counteract the force from the cutting tool. In the case of the grinding, the wheel is fed into the work piece⁵. In the case of the lathe, the cutting tool of critical geometry is fed into the work piece. According to David Morningstar of *Tooling and Production* [1]:

“Many cylindrical grinders are laid out on a pattern similar to a lathe. Instead of a tool holder, they have a mechanism to feed the grinding wheel and its associate machinery, but *all* other elements, *head stock*, *tailstock*, *ways* and *bed* are normally quite recognizable to any one familiar with turning machines. The major difference is that the entire work-holding system is usually mounted on a set of ways so it can be traversed past the wheel during the grinding operation...*Plunge* grinding is closer to traditional single point turning in concept, in that the wheel may be fed in and out to generated specific features on the work-piece such as shoulders.”

It is interesting to hear that the main difference between these machines is the tool holder. A simple tool holder should not amount to the gigantic difference in price between grinding machines and metal cutting machines. As stated before the average price for a midsized grinding machine was found to be \$350,000. Metal cutting machines

⁵ This is called *plunge* grinding; there are many other types of external cylindrical grinding but this is the most applicable type for comparative purposes.

of the same size were found to be at the \$75,000 range. In order to see if there any other functional and component differences between OD grinders and lathes we produced the following tables (Table 2.3 and Table 2.4 respectively).

Table 2.3 OD Grinder Components and Functions

COMPONENT	FUNCTION
OD Grinder	Cuts and shapes cylindrical parts
Wheel Head	Provides wheel, spindle support and motion
Spindle	Holds and rotates the cutting tool
Shaft	Rotates the cutting tool
Bearings	Holds shaft and allows rotation
Inner Race	Connects shaft to Bearings
Outer Race	Connects housing to bearings
Separator	Keeps ball bearings in line
Ball	
Bearings	Allows motion between inner and outer race
Spindle Nose	Connects cutting tool to shaft
Spindle Housing	Contains spindle
Front Seal	Prevents incoming contaminants
Rear Seal	Prevents incoming contaminants
Drawbar	Allows spindle nose release
Lubrication	
System	Keeps moving parts from seizing
Coolant System	Protects against heat damage
Spindle Mounts	Provides structural spindle attachments
Wheel	Cutting tool of non-critical geometry
Wheel Mount	Supports the wheel, connects to spindle nose
Body	Provides support for the work piece, cutting tool etc.
Base	Takes most of the machine load
Square Tubes	Provides for additional load support in the base
Bed	Supports the wheel head
	Contains main work piece motion elements (chuck, spindle)
Head Stock	
Spindle	Holds and rotates the cutting tool
Shaft	Rotates the cutting tool
Bearings	Holds shaft and allows rotation
Inner Race	Connects shaft to Bearings
Outer Race	Connects housing to bearings
Separator	Keep ball bearings in line
Ball	
Bearings	Allows motion between inner and outer race
Spindle Nose	Connects cutting tool to shaft
Spindle Housing	Contains spindle
Front Seal	Prevents incoming contaminants
Rear Seal	Prevents incoming contaminants
Spindle Mounts	Provides structural attachment for spindle
Work Piece Holder	Aka "chuck", holds the work piece
Tail Stock	Supports the work piece from the "tail" end
Center	Connects the work piece to the "tail stock"

Ball screws	Connected to table motor
Shaft	Rotates and allows nut movement
Nut	Connects the shaft and the table
Mounts	Support the ball screw on each end
Bearings	Holds shaft and allows rotation
Inner Race	Connects shaft to Bearings
Outer Race	Connects housing to bearings
Separator	Keep ball bearings in line
Ball	
Bearings	Allows motion between inner and outer race
Hydrostatic Way System	Supports and moves the work piece
Way	Saddle track connected to the Base
Base	Stationary member connected to table
Saddle	Moving member and male section.
Fluid Pockets	Fluid Interface for relative way-saddle motion
Fluid Piping	Directs fluid (oil) to pockets
Drive System	Provides motions
Spindle Motor	Provides motion to the grinding wheel
Rotor	Rotating metal
Stator	Stationary magnet
Table Motor	Provides motion to the ball screws
Rotor	Rotating metal
Stator	Stationary magnet
Waste System	Directs the flow of contaminants and chips
Waste Sump	Waste collector
Flushing System	Protects parts from swarf
Control System	Controls speeds, feeds, motions etc.
Grinding Zone Coolant System	Prevents heat damage to parts including work piece
Coolant Pump	Drives the flow of coolant to specific areas
Piping	Directs coolant flow
Coolant Nozzle	Outlet for Coolant
Truing System	Keeps the grinding wheel sharp
Diamond Tip	Grinding wheel cutting tool
Electrical System	Translates and manipulates electrical voltage

Again, with the grinding machine we see that there are truing systems to sharpen the grinding wheel and hydrostatic way systems. In this particular case, there are two main heads, one for rotating the work piece, and one for rotating and moving the grinding wheel. Since grinding is predominantly used for end-product purposes, they must achieve extremely tight tolerances. Most grinders are equipped with linear scales. These linear scales go for approximately \$10,000 a piece. Fran Banfill, Chief Mechanical

Engineer of Service Network Incorporated expresses that some SNI machines are equipped with linear scales (Figure 2.4) on all three axes to provide for ultimate positional feedback accuracy.

Figure 2.4 Linear Scales

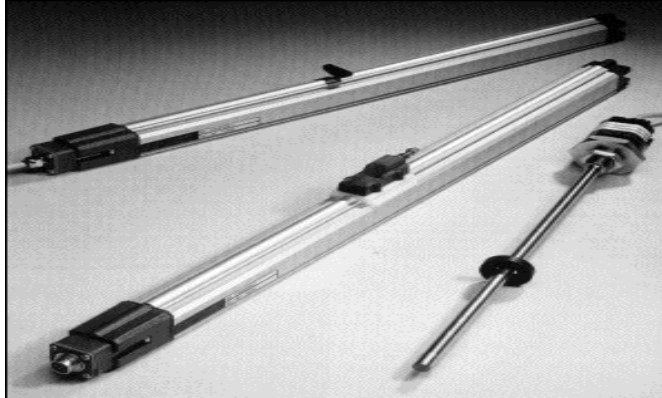

The lathe components and functions are extremely similar to the OD grinder except for a few small details (Table 2.4).

Table 2.4 Lathe Components and Functions

COMPONENT	FUNCTION
Lathe	Cuts and shapes parts cylindrical parts Provides support for the work piece, cutting tool etc.
Body	
Base	Takes most of the machine load
Bed	Supports the work piece table
Table	For supporting and moving loads Contains main work piece motion elements (chuck, spindle)
Head Stock	
Spindle	Holds and rotates the cutting tool
Shaft	Rotates the cutting tool
Bearings	Holds shaft and allows rotation
Inner Race	Connects shaft to Bearings
Outer Race	Connects housing to bearings
Separator	Keep ball bearings in line
Ball Bearings	Allows motion between inner and outer race
Spindle Nose	Connects cutting tool to shaft
Spindle Housing	Contains spindle

Front Seal	Prevents incoming contaminants
Rear Seal	Prevents incoming contaminants
Spindle Mounts	Provides structural attachment for spindle
Work Piece Holder	Aka "chuck", holds the work piece
Tail Stock	Supports the work piece from the "tail" end
Center	Connects the work piece to the "tail stock"
Ball screws	Connected to table motor
Shaft	Rotates and allows nut movement
Nut	Connects the shaft and the table
Mounts	Support the ball screw on each end
Bearings	Holds shaft and allows rotation
Inner Race	Connects shaft to Bearings
Outer Race	Connects housing to bearings
Separator	Keep ball bearings in line
Ball Bearings	Allows motion between inner and outer race
Hardened Steel Way Slides	For tool motion
Way	Saddle tracking wear surface
Base	Stationary member and male section
Saddle	Moving member of slide
Retainer	Retains the saddle to the base
Lubrication Fitting	For pressure gun lubrication
Wiper	Provides protection to way surfaces from contaminants
Gib	Sets clearance between way and saddle
Gib Screws	Used to adjust Gib
Gib Screw Nuts	Locks Gib Screws
Gib Positioning Pin	For linear Gib positioning
Drive System	Provides motion to all moving parts/fluids
Spindle Motor	Drives the spindle via belt
Rotor	Rotating metal
Stator	Stationary magnet
Table Motor	Drives the tool table via ball screw
Rotor	Rotating metal
Stator	Stationary magnet
Waste System	Directs the flow of contaminants and chips
Waste Sump	Waste collector
Piping	Controls speeds, feeds, motions etc. Prevents heat damage to parts including work piece
Control System	
Coolant System	Drives the flow of coolant to specific areas
Coolant Pump	Directs coolant flow
Piping	Outlet for Coolant
Coolant Nozzle	Translates electrical voltages

The lathe is basically a stripped down version of the OD grinder. Here's a better look at OD grinding (Figure 2.4) and turning (Figure 2.5) separately.

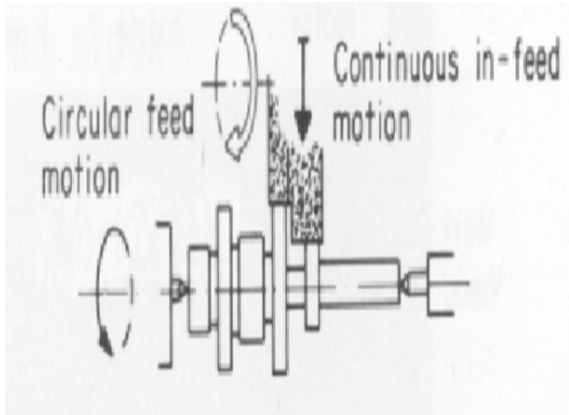

Figure 2.5 OD grinding



Figure 2.6 Lathe cutting tool and chuck

2.4 FURTHERING THE ANALYSIS

Indeed there are many differences between OD grinding and turning. These differences are very similar to that of the OD grinder and milling machine, namely, the ways and base. Unfortunately, with the lack of cost information, it is difficult to pinpoint the cost culprit causing grinding machine prices to soar. Although, we have located some major component and functional differences that may certainly be the cause. In order to further examine differences in the machines and possibly reveal more insight as to why grinding machines are so expensive, we focused on the machines specific technical output difference. Lathes and OD grinders both have work piece motors, but that does not mean that they are rated at the same horsepower. Furthermore, milling machines and surface grinders both have main spindles, but they may run at significantly different speeds. In addition to the componential differences between the machines, the following

chapter will focus on horsepower, speeds, materials used and other significant technical data which may subsequently translate into cost.

3. TECHNICAL OUTPUT COMPARISON

3.1 INTRODUCTION

Since there are thousands of machine tool components and thousands of factors affecting the particular design of a machine tool, we will limit our study to only those of critical importance. We will focus on the drives, the base and the ways and how they may or may not vary between grinding and machine tool machining. We will also touch upon the affect of accuracy and the difference between machine tool controls and grinding controls.

3.2 THE DRIVES

A “drive” is a term often misused. Some people refer to a drive system as a motor a shaft, a gear box and maybe even the electrical components. On the other hand, drives may be considered as the motors only. In our case we will treat the drive as simply the motor. In particular, we will zero in on the main drive as opposed to the feed drives since they take on the brunt of the energy from the cutting zone. Main drives translate to main costs!

3.2.2 THE LATHE AND MILLING MACHINE

From Richard Pohanish’s *Machinery’s Handbook* and George Tlustly’s *Manufacturing Processes and Equipment* it is seen that the milling machine and the lathe require extremely similar cutting speeds for operations of the same quality⁶. For

⁶ In this sense, “quality” is referring to many things: cutting edge material, work piece material, surface finish desired etc.

example, for a high speed steel cutting tool with a AISI 1020 steel work piece and performing a finishing operation, the recommended cutting speed is about 110 feet per minute. Furthermore, the motor power is directly proportional to the cutting speed. We can see this through the following series of Equations taken from SETCO spindle supplemental guides (Equation 3.1).

Equation 3.1 Cutting speed proportional to main spindle motor power⁷.

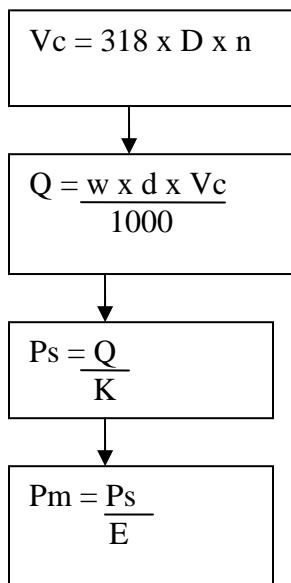

We see here the cutting speed, V_c , is directly proportional to the motor power, P_m . The logic is as follows: The cutting speed, V_c , is proportional to the metal removal rate, Q . The metal removal rate is proportional to the spindle power, P_s . And lastly, the spindle power is proportional to the power needed at the motor P_m .

With this information we can deduce that grinding motors will require *more* power than the machine tool motors since grinding spindles are running at much faster speeds. As result there is *higher* cost. The specific amount of which is still vague due to our lack of cost information. The following sub-chapter reveals some grinding main drive characteristics.

⁷ This also applies to *grinding* cutting speeds and motor powers

3.2.3 THE SURFACE GRINDER AND OD GRINDER

As stated previously grinding spindles run at much higher speeds than metal cutting machine spindles. In addition to requiring higher power motors, the spindles themselves must require special attention. Opposed to most metal cutting machine spindles, grinding spindles have a special through coolant design, ceramic balls and constant lubrication to allow for their increased speeds. This dramatically increases the cost. Some other features unique to grinding spindles include: heat treated components, precise dynamic balancing of all rotating parts and high efficiency motors. Furthermore, Grinding spindles are much stiffer than machine tool spindles to account for grindings quality needs.

In his book, *Design of Machine Tools*, Olaf Johnson [5] notes that higher horsepower motors have bigger frames. Furthermore, Mr. Johnson states the lower the rpm per horsepower, the smaller the frames. Again, grinding machines require more horsepower and bigger frames which result in more material and higher cost.

3.3 THE GUIDEWAY SYSTEM

The major difference between grinding machines and metal cutting machines is the guide-way system. Where metal cutting machines have guide-way systems consisting of roller type bearing elements and lots of metal to metal contact, grinding machines have hydrostatic ways where there is no metal to metal contact at all. The only time metal to metal contact occurs when the hydrostatic system is shut down, the fluid pressure drops to zero and the table saddle rests on the ways.

Within the hydrostatic system there are capillary coils for pressurized oil flow and five micron filtering devices to block out contaminants. It should be noted that with the hydrostatic system will last much longer than the roller bearing element system. The roller bearing element system may also cause for more noise and vibrations due to the metal to metal contact. Furthermore, the roller system provides much less dampening properties than that of the hydrostatic. For that reason, most machine tools with roller element guide-ways will have a cast iron base.

3.4 THE BASE

In this study, grinding machines with hydrostatic way systems did not necessitate ultra stiff bases such as those made of granite or cast iron. This is due to the fact that most of the vibration dampening is taken care of through the hydrostatic system. On the other hand, machine tools with roller element guide-ways provide less dampening and cast iron bases are needed. Grinding machines with hydrostatic ways have a fabricated and welded steel base to reduce cost.

3.5 ACCURACY

Accuracy is probably the number one design consideration in machine tools. This is because machine tools *rely* on part accuracy to keep up with the demand for tighter tolerances in industry. It's simply a matter of business. In an interview by Automotive Design and Production [6], Nelson Beaulieu, accounts manager of United Grinding Technologies elaborates on the increased demand for tighter tolerances. He lists a slew

of parts that “ought” to be more ground instead of machined, from drive train yolks to torque converter components. The automotive, aerospace and medical fields are just a few examples of the many industries where tighter tolerances are becoming of great importance. The following figure shows the many aspects of machine tools that accuracy governs (Fig. 3.1).

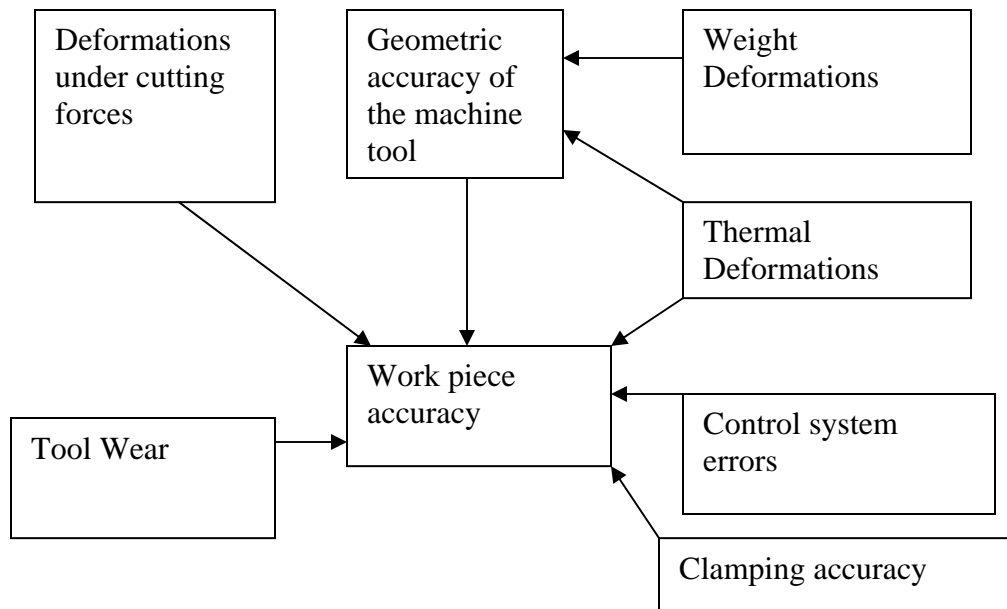

Figure 3.1 Work-piece accuracy

With this in mind coupled with the fact that grinding machine builders strive for extremely high accuracy, it is easy to see how expenses can rise exponentially as stated earlier. As shown, the control system can be modified, the clamping unit can be modified, and different materials can be used to reduce thermal deformations and so on. All these modifications result in greater cost.

3.6 CONTROLS

The contributing editor of Tooling and Production [2] notes the differences between machine tool controls and grinding controls:

“The fact that both the tool and work-piece are normally moving makes analysis and control of grinding operations considerably more complex than is the case with milling or turning. This is part of the reason why grinding has been one of the last of the major metal working processes to make the transition from “black art” to science, and incidentally, one of the main reasons why many grinder manufacturers still tend to design and build their own CNC controls”

Since controls are all unique, they’re most likely more expensive as opposed to production made controls like those of Haas automation Inc. In the case of the Service Network Inc. they design their own control software.

4. RESULTS

After analyzing our results, it became evident that there were two main factors that contributed to the large cost difference between grinding machines and machining machines. They were found to be volume of production and the precision of the components.

4.1 VOLUME

Grinding machines are usually built on an order specific basis, since most are used for specific production purposes. Production of a specific machine will be in the 10s or at most 100s in terms of numbers, while comparable production milling and turning machines can reach into the 1000s. The lower volume of machines being manufactured, the higher the cost becomes. This is because the design cost is spread out over a fewer number of machines. For example, we can look at the data when RBC bearings developed its own grinding machine, the Torrington Predator NTS. In its first production of a single machine, the cost was \$340,000. When the decision was made to produce more machines later that year, with an order size of 10 machines, the price dropped to \$197,000 per machine. This was due to the design cost being spread out over a greater number of machines, and also production cost to manufacture a single component verse a batch of components. With an increased order size, the company was able to use outside vendors who could manufacture the batch of components cheaper than a vendor who would only manufacture a single component.

4.2 PRECISION

Grinding machines are capable of producing end products with superior finishes, and to more precise tolerances. These abilities come at cost due to the extra development, design, setup costs, and once again volume of production of these parts. Parts become cheaper when they can be made in a batch process, and are more expensive when they are individually manufactured. As parts become more specialized and unique, the costs increase because they are often handmade, instead of stock pieces which can be ordered.

5. CONCLUSIONS

In conclusion, while individual component costs are larger for grinding machines, we are lead to believe that this all comes down to the limited demand for the parts. Economics seems to be the major driving force in the difference in costs of grinding and machining in the current industry. Also, when considering the same material and performance capabilities, there is no significant difference in price between the two methods. Grinding machines are often more specialized and have greater performance tolerances, and so have a higher average price.

One problem with trying to expand the grinding industry is that the majority of pieces that are manufactured don't require tight tolerances, or superb surface finishes. Because of this, machining machines are more popular due to their decreased cost. If the grinding industry can come up with a way to assemble grinding machines with more common parts, and in larger order quantities, then they may be able to capture more of the market.

REFERENCES

- [1] D. Morningstar, *Anatomy of a Machine Tool*, **Tooling and Production**, 1994 ed. pp. 41-42.
- [2] Setco, Supplemental Guide, 2005.
- [3] N. Beaulieu, *Profit Processing Scenarios*, **Tooling and Production**, 2006.
- [4] Haas online, <http://www.haascnc.com/home.asp>.

BIBLIOGRAPHY

- Johnson, **Design of Machine Tools**, Philadelphia: Chilton Book Company, 1971.
- Hahn and King, **Handbook of Modern Grinding Technology**, Auburn: Service Network Inc., 1998.
- Miller and Miller, **Machine Shop Tools and Operations**, 5th ed. US: Wiley, 2004.
- Plusty, **Manufacturing Processes and Equipment**, New Jersey: Prentice Hall, 2000.
- Weck, **Handbook of Machine Tools**, v1. New York: John Wiley and Sons, 1984.